



HAL
open science

Large multipliers with less DSP blocks

Florent de Dinechin, Bogdan Pasca

► **To cite this version:**

Florent de Dinechin, Bogdan Pasca. Large multipliers with less DSP blocks. Field Programmable Logic and Applications, Aug 2009, Czech Republic. ensl-00356421

HAL Id: ensl-00356421

<https://ens-lyon.hal.science/ensl-00356421>

Submitted on 27 Jan 2009

HAL is a multi-disciplinary open access archive for the deposit and dissemination of scientific research documents, whether they are published or not. The documents may come from teaching and research institutions in France or abroad, or from public or private research centers.

L'archive ouverte pluridisciplinaire **HAL**, est destinée au dépôt et à la diffusion de documents scientifiques de niveau recherche, publiés ou non, émanant des établissements d'enseignement et de recherche français ou étrangers, des laboratoires publics ou privés.

Large multipliers with less DSP blocks

LIP research report RR2009-03

Florent de Dinechin, Bogdan Pasca *
LIP (CNRS/INRIA/ENS-Lyon/UCBL)
École Normale Supérieure de Lyon — Université de Lyon
Florent.de.Dinechin@ens-lyon.fr

Abstract

Recent computing-oriented FPGAs feature DSP blocks including small embedded multipliers. A large integer multiplier, for instance for a double-precision floating-point multiplier, consumes many of these DSP blocks. This article studies three non-standard implementation techniques of large multipliers: the Karatsuba-Ofman algorithm, non-standard multiplier tiling, and specialized squarers. They allow for large multipliers working at the peak frequency of the DSP blocks while reducing the DSP block usage. Their overhead in term of logic resources, if any, is much lower than that of emulating embedded multipliers. Their latency overhead, if any, is very small. Complete algorithmic descriptions are provided, carefully mapped on recent Xilinx and Altera devices, and validated by synthesis results.

1 Introduction

A paper-and-pencil analysis of FPGA peak floating-point performance [8] clearly shows that DSP blocks are a relatively scarce resource when one wants to use them for accelerating double-precision (64-bit) floating-point applications.

This article presents techniques reducing DSP block usage for large multipliers. Here, “large” means: any multiplier that, when implemented using DSP blocks, consumes more than two of them, with special emphasis on

the multipliers needed for single-precision (24-bit) and double-precision (53-bit) floating-point.

There are many ways of reducing DSP block usage, the simplest being to implement multiplications in logic only. However, a LUT-based large multiplier has a large LUT cost (at least n^2 LUTs for n -bit numbers, plus the flip-flops for pipelined implementations). In addition, there is also a large performance cost: a LUT-based large multiplier will either have a long latency, or a slow clock. Still, for some sizes, it makes sense to implement as LUTs some of the sub-multipliers which would use only a fraction of a DSP block.

We focus here on algorithmic reduction of the DSP cost, and specifically on approaches that consume few additional LUTs, add little to the latency (and sometime even reduce it), and operate at a frequency close to the peak DSP frequency.

All the results in this article have been obtained using ISE 9.2i / LogiCore Multiplier 10.0.

Contributions

After an introduction in Section 2 to the implementation large multipliers in DSP-enhanced FPGAs, this article has three distinct contributions.

Section 3 studies the Karatsuba-Ofman algorithm [5, 6, 7], commonly used¹ in multiple-precision software and, on FPGAs, large multiplication in finite fields. This algorithm trades multiplications for additions, thus reducing

*This work was partly supported by the XtremeData university programme and the ANR EVAFlo and TCHATER projects.

¹We were surprised to find no reference to Karatsuba-Ofman for integer multiplication in the FPGA literature and will be deeply grateful to the referees for any pointer to prior work on FPGAs.

the DSP cost of large multipliers from 4 to 3, from 9 to 6, or from 16 to 10. This technique works for any DSP-enhanced FPGA from Xilinx or Altera, but is actually less efficient on more recent chips, which are less flexible.

Section 4 introduces a tiling-based technique that widens the multiplier design space on Virtex-5 (or any circuit featuring rectangular multipliers). It is illustrated by two original multipliers, a 41-bit one in 4 DSP48E and a 58-bit one in 8 DSP48E, suitable for double-precision.

Finally, Section 5 focuses on the computation of squares. Squaring is fairly common in FPGA-accelerated computations, as it appears in norms, statistical computations, polynomial evaluation, etc. A dedicated squarer saves as many DSP blocks as the Karatsuba-Ofman algorithm, but without its overhead.

For each of these techniques, we present an algorithmic description followed by a discussion of the match to DSP blocks of relevant FPGA devices, and experimental results.

2 Context and state of the art

2.1 Large multipliers using DSP blocks

Let k be an integer parameter, and let X and Y be $2k$ -bit integers to multiply. We will write them in binary $X = \sum_{i=0}^{2k-1} 2^i x_i$ and $Y = \sum_{i=0}^{2k-1} 2^i y_i$.

Let us now split each of X and Y into two subwords of k bit each:

$$X = 2^k X_1 + X_0 \quad \text{and} \quad Y = 2^k Y_1 + Y_0$$

X_1 is the integer formed by the k most significant bits of X , and X_0 is made of the k least significant bits of X .

The product $X \times Y$ may be written

$$X \times Y = (2^k X_1 + X_0) \times (2^k Y_1 + Y_0)$$

or

$$XY = 2^{2k} X_1 Y_1 + 2^k (X_1 Y_0 + X_0 Y_1) + X_0 Y_0 \quad (1)$$

This product involves 4 sub-products. If k is the input size of an embedded multiplier, this defines an architecture for the $2k$ multiplication that requires 4 embedded multipliers. This architecture can also be used for any input size between $k + 1$ and $2k$. Besides, it can be generalized: For

any $p > 1$, numbers of size between $pk - k + 1$ and pk may be decomposed into p k -bit numbers, leading to an architecture consuming p^2 embedded multipliers.

Earlier FPGAs had only embedded multipliers, but the more recent DSP blocks [10, 9, 1, 2] include internal adders designed in such a way that most of the additions in Equation (1) can also be computed inside the DSP blocks. Let us now review these features in current mainstream architectures, focussing on the capabilities of the DSP blocks relevant to this paper.

2.2 Overview of DSP block architectures

The Virtex-4 DSP block (DSP48) contains one signed 18x18 bit multiplier followed by a 48-bit addition/subtraction unit [10]. As the multiplier decomposition (1) involves only positive numbers, the multipliers must be used as unsigned 17-bit multipliers, so for these devices we will have $k = 17$. The multiplier output may be added to the output of the adder from the previous DSP48 in the row (using the dedicated PCOUT/PCIN port), possibly with a fixed 17-bit shift – this allows for 2^{17} factors as in Equation (1).

In Virtex-5 DSP blocks (DSP48E), the 18x18 multipliers have been replaced with asymmetrical ones (18x25 bits signed). This reduces the DSP cost of floating-point single-precision (24-bit significand) from 4 to 2. The fixed shift on PCIN is still 17-bit only [9]. Another improvement is that the addition unit is now capable of adding a third term coming from global routing.

The Stratix II DSP block consists of four 18x18 multipliers which can be used independently. It also includes two levels of adders, enabling the computation of a complete 36x36 product or a complete 18-bit complex product in one block [1]. With respect to this article, the main advantage it has over the Virtex-4 is the possibility to operate on *unsigned* 18-bit inputs: Altera devices may use $k = 18$, which is an almost perfect match for double-precision (53-bit significand) as $54 = 3 \times 18$.

In Stratix III, the previous blocks are now called half-DSP blocks and are grouped by two [2]. A half-DSP block contains 4 18x18 multipliers, 2 36-bit adders and one 44-bit adder/accumulator, which can take its input from the half-DSP block just above. This direct link enables in-DSP implementation of some of the additions of (1). Unfortunately, the Stratix-III half-DSP is much less

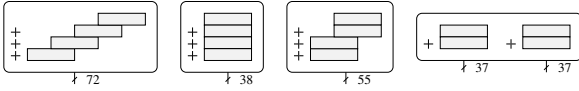

Figure 1: Stratix-III and IV operating modes using four 18x18 multipliers. Each rectangle is the 36-bit output of an 18x18 multiplier. All constant shifts are multiples of 18 bits.

flexible than the Stratix-II DSP. Indeed, its output size is limited, meaning that the 36x36 multiplier of a half-DSP may not be split as four *independent* 18x18 multipliers. More precisely, the four input pairs may be connected independently, but the output is restricted to one of the addition patterns described by Figure 1. The Stratix IV DSP block is mostly identical to the Stratix III one.

All these DSP blocks also contain dedicated registers that allow for pipelined designed at high frequencies (from 300 to 600 MHz depending on the generation).

3 Karatsuba-Ofman algorithm

3.1 Two-part splitting

The classical step of Karatsuba-Ofman algorithm is the following. First compute $D_X = X_1 - X_0$ and $D_Y = Y_1 - Y_0$. The results are signed numbers that fit on $k + 1$ bits². Then compute the product $D_X \times D_Y$ using a DSP block. Now the middle term of equation (1), $X_1Y_0 + X_0Y_1$, may be computed as:

$$X_1Y_0 + X_0Y_1 = X_1Y_1 + X_0Y_0 - D_X D_Y \quad (2)$$

Then, the computation of XY using (1) only requires three DSP blocks: one to compute X_1Y_1 , one for X_0Y_0 , and one for $D_X D_Y$.

There is an overhead in terms of additions. In principle, this overhead consists of two k -bit subtractions for computing D_X and D_Y , plus one $2k$ -bit addition and one $2k$ -bit subtraction to compute equation (2). There are still more additions in equation (1), but they also have to be

²There is an alternative Karatsuba-Ofman algorithm computing $X_1 + X_0$ and $Y_1 + Y_0$. We present the subtractive version, because it enables to use the Xilinx 18-bit signed-only multipliers fully, while working on Altera chips as well.

	latency	freq.	slices	DSPs
Logicore	6	518	43	4
Logicore	3	176	17	4
K-O-2	3	518	100	3

Table 1: 34x34 multipliers on Virtex-4 (4vlx15sf363-12)

computed by the classical multiplication decomposition, and are therefore not counted in the overhead.

Counting one LUT per adder bit³, and assuming that the $k - bit$ addition in LUT can be performed at the DSP operating frequency, is we get a theoretical overhead of $6k$ LUT. However, the actual overhead is difficult to predict exactly, as it depends on the scheduling of the various operations, and in particular in the way we are able to exploit registers and adders insided DSPs. There may also be an overhead in terms of latency, but we will see that the initial subtraction latency may be hidden, while the additional output additions may take the place of the saved multiplier.

At any rate, these overheads are much smaller than the overheads of emulating one multiplier with LUTs at the peak frequency of the DSP blocks. Let us now illustrate this discussion with a practical implementation on a Virtex-4.

3.2 Implementation issues on Virtex-4

The fact that the differences D_X and D_Y are now signed 18-bit is actually a perfect match for a Virtex-4 DSP block.

Figure 2 presents the architecture chosen for implementing the previous multiplication on a Virtex-4 device. The shift-cascading feature of the DSPs allows the computation of the right-hand side of equation (2) inside the three DSPs at the cost of a 2k-bit subtraction needed for recovering X_1Y_1 . Notice that here, the pre-subtractions do not add to the latency.

This architecture was described in VHDL (using $+$ and $*$ from the `ieee.std_logic_arith` package), tested, and synthesized. The corresponding results are given in Table 1. Some tweaking of the options was

³In all the following we will no longer distinguish additions from subtractions, as they have the same LUT cost in FPGAs.

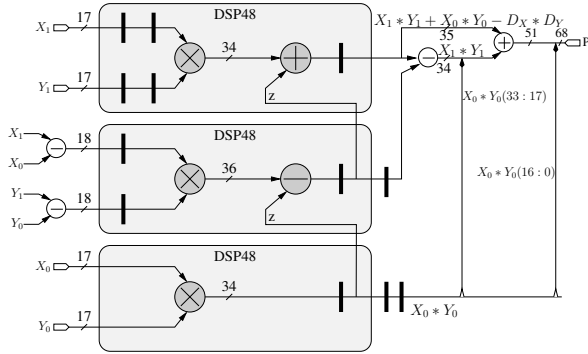

Figure 2: 34x34bit multiplier using Virtex-4 DSP48

needed, for instance to prevent using the much slower SRL16 to implement the registers.

3.3 Three-part splitting

Now consider two numbers of size $3k$, decomposed in three subwords each:

$$X = 2^{2k}X_2 + 2^kX_1 + X_0 \quad \text{and} \quad Y = 2^{2k}Y_2 + 2^kY_1 + Y_0$$

We have

$$\begin{aligned} XY &= 2^{4k}X_2Y_2 \\ &+ 2^{3k}(X_2Y_1 + X_1Y_2) \\ &+ 2^{2k}(X_2Y_0 + X_1Y_1 + X_0Y_2) \\ &+ 2^k(X_1Y_0 + X_0Y_1) \\ &+ X_0Y_0 \end{aligned} \quad (3)$$

After precomputing $X_2 - X_1$, $Y_2 - Y_1$, $X_1 - X_0$, $Y_1 - Y_0$, $X_2 - X_0$, $Y_2 - Y_0$, we compute (using DSP blocks) the six products

$$\begin{aligned} P_{22} &= X_2Y_2 & P_{21} &= (X_2 - X_1) \times (Y_2 - Y_1) \\ P_{11} &= X_1Y_1 & P_{10} &= (X_1 - X_0) \times (Y_1 - Y_0) \\ P_{00} &= X_0Y_0 & P_{20} &= (X_2 - X_0) \times (Y_2 - Y_0) \end{aligned}$$

and equation (3) may be rewritten as

$$\begin{aligned} XY &= 2^{4k}P_{22} \\ &+ 2^{3k}(P_{22} + P_{11} - P_{21}) \\ &+ 2^{2k}(P_{22} + P_{11} + P_{00} - P_{20}) \\ &+ 2^k(P_{11} + P_{00} - P_{10}) \\ &+ P_{00} \end{aligned} \quad (4)$$

	latency	freq.	slices	DSPs
LogiCore	11	518	156	9
LogiCore	6	264	94	9
K-O-3	6	340	337	6

Table 2: 51x51 multipliers on Virtex-4 (4vlx15sf363-12).

Here we have reduced DSP usage from 9 to 6 which, according to Montgomery [7], is optimal. There is a first overhead of $6k$ LUTs for the pre-subtractions (again, each DSP is traded for $2k$ LUTs). Again, the overhead of the remaining additions is difficult to evaluate. Most may be implemented inside DSP blocks. However, as soon as we need to use the result of a multiplication twice (which is the essence of Karatsuba-Ofman algorithm), we can no longer use the internal adder behind this result, so LUT cost goes up. Table 2 provides some synthesis results. The critical path is in one of the $2k$ -bit additions, and could be reduced by pipelining them.

3.4 Four-part splitting and more

We present this last section for completeness, but it is probably less useful: The most recent FPGA families by Xilinx and Altera do not need it for an efficient implementation of double-precision multiplication. 3-part splitting is enough thanks to unsigned 18-bit multiplication on Altera, using 9 or 6 DSP blocks depending on Karatsuba algorithm or not. On Virtex-5, the multiplier structure presented in Section 4 consumes only 8 or 9 DSP48E.

Classically, the Karatsuba idea may be applied recursively: A 4-part splitting is obtained by two levels of 2-part splitting. However, a direct expression allows for a more straightforward implementation. From

$$\begin{aligned} X &= 2^{3k}X_3 + 2^{2k}X_2 + 2^kX_1 + X_0 \\ Y &= 2^{3k}Y_3 + 2^{2k}Y_2 + 2^kY_1 + Y_0 \end{aligned}$$

we have

$$\begin{aligned}
XY &= 2^{6k} X_3 Y_3 \\
&+ 2^{5k} (X_2 Y_3 + X_3 Y_2) \\
&+ 2^{4k} (X_3 Y_1 + X_2 Y_2 + X_1 Y_3) \\
&+ 2^{3k} (X_3 Y_0 + X_2 Y_1 + X_1 Y_2 + X_0 Y_3) \\
&+ 2^{2k} (X_2 Y_0 + X_1 Y_1 + X_0 Y_2) \\
&+ 2^k (X_1 Y_0 + X_0 Y_1) \\
&+ X_0 Y_0
\end{aligned} \quad (5)$$

Here we compute (using DSP blocks) the products

$$\begin{aligned}
P_{33} &= X_3 Y_3 \\
P_{22} &= X_2 Y_2 \\
P_{11} &= X_1 Y_1 \\
P_{00} &= X_0 Y_0 \\
P_{32} &= (X_3 - X_2) \times (Y_3 - Y_2) \\
P_{31} &= (X_3 - X_1) \times (Y_3 - Y_1) \\
P_{30} &= (X_3 - X_0) \times (Y_3 - Y_0) \\
P_{21} &= (X_2 - X_1) \times (Y_2 - Y_1) \\
P_{20} &= (X_2 - X_0) \times (Y_2 - Y_0) \\
P_{10} &= (X_1 - X_0) \times (Y_1 - Y_0)
\end{aligned}$$

and equation (5) may be rewritten as

$$\begin{aligned}
XY &= 2^{6k} P_{33} \\
&+ 2^{5k} (P_{33} + P_{22} - P_{32}) \\
&+ 2^{4k} (P_{33} + P_{22} + P_{11} - P_{31}) \\
&+ 2^{3k} (P_{33} + P_{00} - P_{30} + P_{22} + P_{11} - P_{21}) \\
&+ 2^{2k} (P_{22} + P_{11} + P_{00} - P_{20}) \\
&+ 2^k (P_{11} + P_{00} - P_{10}) \\
&+ P_{00}
\end{aligned} \quad (6)$$

Here we have only 10 multiplications instead of 16. Note that the recursive variant saves one more multiplication: It precomputes

$$P_{3210} = (X_3 + X_2 + X_1 + X_0) \times (Y_3 + Y_2 + Y_1 + Y_0)$$

instead of P_{30} and P_{21} , and computes the middle term $X_3 Y_0 + X_2 Y_1 + X_1 Y_2 + X_0 Y_3$ of equation (5) as a sum of P_{3210} and the other P_{ij} . However this poses several problems. Firstly, we have to use a smaller k (splitting in smaller chunks) to ensure P_{3210} doesn't overflow from the DSP size. Secondly, we currently estimate that the saved DSP is not worth the critical path degradation.

A reader interested in even larger multipliers should read Montgomery's study [7].

3.5 Issues with the most recent devices

The Karatsuba-Ofman algorithm is useful on Virtex-II to Virtex-4 as well as Stratix-II devices, to implement single and double precision floating-point.

The larger (36 bit) DSP block granularity (see Section 2.2) of Stratix-III and Stratix-IV prevents us from using the result of a 18x18 bit product twice, as needed by the Karatsuba-Ofman algorithms. This pushes their relevance to multipliers classically implemented as at least four 36x36 half-DSPs. The additive version should be considered, as it may improve speed by saving some of the sign extensions. The frequency will be limited by the input adders if they are not pipelined or implemented as carry-select adders.

On Virtex-5 devices, the Karatsuba-Ofman algorithm can be used if each embedded multiplier is considered as a 18x18 one, which is suboptimal. For instance, single precision K-O requires 3 DSP blocks, where the classical implementation consumes 2 blocks only. We still have to find a variant of Karatsuba-Ofman that exploits the 18x25 multipliers to their full potential. X may be split in 17-bit chunks and Y in 24-bit chunks, but then, in Equation (2), D_X and D_Y are two 25-bit numbers, and their product will require a 25x25 multiplier.

We now present an alternative multiplier design technique specific to Virtex-5 devices.

4 Non-standard tilings

This section optimizes the use of the Virtex-5 25x18 signed multipliers. In this case, X has to be decomposed into 17-bit chunks, while Y is decomposed into 24-bit chunks. Indeed, in the Xilinx LogiCore Floating-Point Generator, version 3.0, a double-precision floating-point multiplier consumed 12 DSP slices: X was split into 3 24-bit subwords, while Y was split into 4 17-bit subwords. This splitting would be optimal for a 72x68 product, but quite wasteful for the 53x53 multiplication required for double-precision, as illustrated by Figure 3(a). In version 4.0, some of the smaller sub-multipliers have been expressed as additions and replaced with either LUT logic or internal DSP adders (the details are not published), reducing the count to 9 or 10 DSP slices. However, a 53-bit integer multiplier in LogiCore 10 still consumes 12

DSP48E.

The following equation presents an original way of implementing double-precision (actually up to 58x58) multiplication, using only eight 18x25 multipliers.

$$\begin{aligned}
 XY &= X_{0:23}Y_{0:16} & (M1) \\
 &+ 2^{17}(X_{0:23}Y_{17:33}) & (M2) \\
 &+ 2^{17}(X_{0:16}Y_{34:57}) & (M3) \\
 &+ 2^{17}(X_{17:33}Y_{34:57})) & (M4) \\
 &+ 2^{24}(X_{24:40}Y_{0:23}) & (M8) \\
 &+ 2^{17}(X_{41:57}Y_{0:23}) & (M7) \\
 &+ 2^{17}(X_{34:57}Y_{24:40}) & (M6) \\
 &+ 2^{17}(X_{34:57}Y_{41:57})) & (M5) \\
 &+ 2^{48}(X_{24:33}Y_{24:33}) &
 \end{aligned}
 \tag{7}$$

The reader may check that each multiplier is a 17x24 one except the last one. The proof that Equation (7) indeed computes $X \times Y$ consists in considering

$$X \times Y = \left(\sum_{i=0}^{57} 2^i x_i \right) \times \left(\sum_{j=0}^{57} 2^j y_j \right) = \sum_{i,j \in \{0 \dots 57\}} 2^{i+j} x_i y_j$$

and checking that each partial bit product $2^{i+j} x_i y_j$ appears once and only once in the right-hand side of Equation (7). This is illustrated by Figure 3(b).

The last line of Equation (7) is a 10x10 multiplier (the white square at the center of Figure 3(b)). It could consume an embedded multiplier, but is probably best implemented as logic.

Equation (7) has been parenthesized to make the best use of the DSP48E internal adders: we have two parallel cascaded additions with 17-bit shifts.

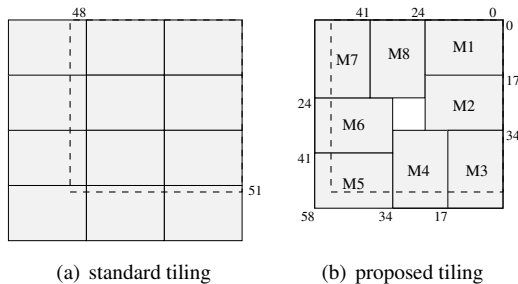

Figure 3: 53-bit multiplication using Virtex-5 DSP48E. The dashed square is the 53x53 multiplication.

	latency	Freq.	REGs	LUTs	DSPs
LogiCore	14	655	348	297	12
LogiCore	8	337	297	222	12
LogiCore	4	115	137	34	12
Tiling	4	369	243	400	8

Table 3: 58x58 multipliers on Virtex-5 (5vlx30ff324-3). Results for 53-bits are almost identical. However, this table misses a serious contender: the multiplier used in LogiCore Floating-Point Operator 4.0, which is unfortunately not available separately as an integer multiplier

This design was implemented in VHDL, tested, and synthesized. Preliminary synthesis results are presented in Table 3. The critical path is in the final addition, currently implemented as LUTs. It could probably exploit the 3-input addition capabilities of DSP48E instead. Or it could be pipelined to reach the peak DSP48E frequency, at the cost of one more cycle of latency. The LUT cost is also larger than expected, even considering that the 10x10 multiplier is implemented in LUTs and pipelined.

Figure 4 illustrates a similar idea for 41x41 and for 65x65 multiplications – the corresponding equations are left as an exercise to the reader. The 65x65 example (which may even be used up to 68x65) shows that a tiling doesn't have to be regular.

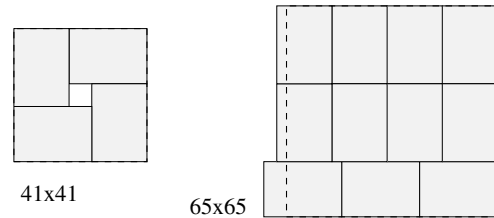

Figure 4: Tilings for 41x41 and 65x65 multiplications.

5 Squarers

The bit-complexity of squaring is roughly half of that of standard multiplication. Indeed, we have the identity:

$$\begin{aligned} X^2 &= \left(\sum_{i=0}^{n-1} 2^i x_i \right)^2 \\ &= \sum_{i=0}^{n-1} 2^{2i} x_i^2 + \sum_{0 < i < j < n} 2^{i+j} x_i x_j \end{aligned}$$

This is only useful if the squarer is implemented as LUTs. However, a similar property holds for a splitting of the input into several subwords:

$$(2^k X_1 + X_0)^2 = 2^{2k} X_1^2 + 2 \cdot 2^k X_1 X_0 + X_0^2 \quad (8)$$

$$\begin{aligned} (2^{2k} X_2 + 2^k X_1 + X_0)^2 &= 2^{4k} X_2^2 + 2^{2k} X_1^2 + X_0^2 \\ &+ 2 \cdot 2^{3k} X_2 X_1 \\ &+ 2 \cdot 2^{2k} X_2 X_0 \\ &+ 2^k X_1 X_0 \end{aligned} \quad (9)$$

Computing each square or product of the above equation in a DSP block, there is again a reduction of the DSP count from 4 to 3, or from 9 to 6. Besides, this time, it comes at no arithmetic overhead.

5.1 Squarers on Virtex-4 and Stratix-II

Now consider $k = 17$ for a Virtex-4 implementation. Looking closer, it turns out that we still lose something using the above equations: The cascading input of the DSP48 and DSP48E is only able to perform a shift by 17. We may use it only to add terms whose weight differs by 17. Unfortunately, in equation (8) the powers are 0, 18 and 34, and in equation (9) they are 0, 18, 34, 35, 42, 64.

One more trick may be used for integers of at most 33 bits. Equation (8) is rewritten

$$(2^{17} X_1 + X_0)^2 = 2^{34} X_1^2 + 2^{17} (2X_1) X_0 + X_0^2 \quad (10)$$

and $2X_1$ is computed by shifting X_1 by one bit before inputting it in the corresponding DSP. We have this spare bit if the size of X_1 is at most 16, *i.e.* if the size of X is at most 33. As the main multiplier sizes concerned by such techniques are 24 bit and 32 bit, the limitation to 33 bits is not a problem in practice.

Table 4 provides synthesis results for 32-bit squares on a Virtex-4. Such a squarer architecture can also be fine-tuned to the Stratix II-family.

5.2 Squarers on Stratix-III and Stratix-IV

On the most recent Altera devices, the 36-bit granularity means that the previous technique begins to save DSP blocks only for very large input sizes.

We now present an alternative way of implementing a double-precision (53-bit) squarer on such devices using only two 36x36 half-DSPs, where a standard multiplier requires four on a Stratix-III and two and a half on a Stratix-IV. It exploits the fact that, although the addition structure of the four 18x18 sub-multipliers is fixed, their inputs are independent.

The two 36x36 multipliers we need are illustrated on Figure 5. The upper-right one is completely standard and computes the subsquare $X_{0:35} X_{0:35}$. The bottom-left one (labelled P) is configured as a multiplier, too, but it doesn't need to recompute and add the sub-product $X_{18:35} X_{18:35}$ (the dark square in the center), which was already computed by the previous multiplier. Instead, this sub-multiplier will complete the 53-bit square by computing $2X_{0:17} X_{36:53}$ (the sum of the two white squares), which has the same weight 2^{36} . To this purpose, the inputs of the corresponding 18x18 sub-multiplier have to be set as $X_{0:17}$ and $2X_{36:53}$. The latter will not overflow, because a double-precision significand product is 53x53 and not 54x54, therefore we have $X_{53} = 0$.

We have not yet validated this squarer experimentally. Compared to a standard multiplier, there should be no LUT increase.

Applied to a single 36x36 block, a similar technique allows us to compute squares up to 35x35 using only three of the four 18x18 blocks. The fourth block is unusable, but this may reduce power consumption.

	latency	frequency	slices	DSPs
LogiCore	6	518	40	4
LogiCore	3	176	17	4
Squarer	3	268	20	3

Table 4: 32-bit squarers on Virtex-4 (4vlx15sf363-12)

5.3 Non-standard tilings on Virtex-5

Figure 6 illustrates non-standard tilings for double-precision square using six or five 24x17 multiplier blocks.

Remark that these tilings are symmetrical with respect to the diagonal, so that each symmetrical multiplication may be computed only once. However, there are slight overlaps on the diagonal: the darker squares are computed twice, and therefore the corresponding sub-product must be removed. These tilings are designed in such a way that all the smaller sub-products may be computed in LUTs at the peak DSP frequency.

The equations are therefore the following:

$$\begin{aligned}
 X^2 &= X_{0:16}X_{0:16} & (M1) \\
 &+ 2^{34}X_{17:33}X_{17:33} & (M2) \\
 &+ 2^{72}X_{36:52}X_{36:52} & (M3) \\
 &+ 2 \times 2^{17}X_{0:16}X_{17:35} & (M4) \\
 &+ 2 \times 2^{19+34}X_{19:35}X_{34:52} & (M5) \\
 &- 2^{34+34}X_{34:35}X_{34:35} & (LUT) \\
 &+ 2 \times 2^{36}X_{0:18}X_{36:52} & (M6) \\
 &+ 2 \times 2^{17+34}X_{17:18}X_{34:35} & (LUT)
 \end{aligned} \tag{11}$$

$$\begin{aligned}
 X^2 &= X_{0:16}X_{0:18} & (M1) \\
 &+ 2^{17}X_{17:18}X_{0:18} & (LUT) \\
 &+ 2^{48}X_{24:40}X_{24:40} & (M2) \\
 &+ 2 \times 2^{17}X_{0:23}X_{19:35} & (M3) \\
 &- 2^{19+19}X_{19:23}X_{19:23} & (LUT) \\
 &+ 2 \times 2^{36}X_{0:23}X_{36:52} & (M4) \\
 &+ 2 \times 2^{24+41}X_{24:47}X_{41:52} & (M5) \\
 &- 2^{41+41}X_{41:47}X_{41:47} & (LUT) \\
 &+ 2^{48+48}X_{48:52}X_{48:52} & (LUT)
 \end{aligned} \tag{12}$$

Note that a square multiplication on the diagonal of size n , implemented as LUT, should consume only $n(n+1)/2$ LUTs instead of n^2 thanks to symmetry.

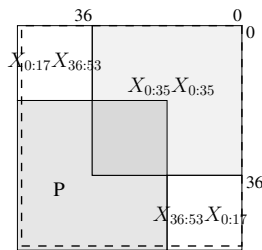

Figure 5: Double-precision squarer for Stratix-III and IV

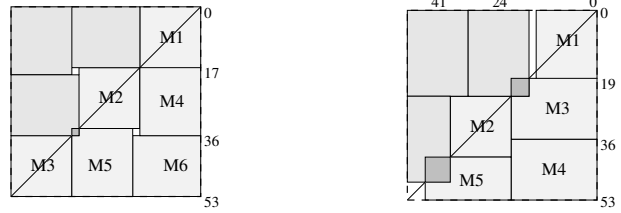

Figure 6: Double-precision squaring on Virtex-5. Left: tiling corresponding to Equation (11). Right: tiling corresponding to Equation (12).

We currently do not have implementation results. It is expected that implementing such equations will lead to a large LUT cost, partly due to the many sub-multipliers, and partly due to the irregular weights of each line (no 17-bit shifts) which may prevent optimal use of the internal adders of the DSP48E blocks.

6 Conclusion

This article has shown that precious DSP resources can be saved in several situations by exploiting the flexibility of the FPGA target. An original family of multipliers for Virtex-5 is also introduced, along with original squarer architectures. The reduction in DSP usage sometimes even entails a reduction in latency. We believe that the place of some of these algorithms is in vendor core generators and synthesis tools, where they will widen the space of implementation trade-off offered to a designer.

The fact that the Karatsuba-Ofman technique is poorly suited to the larger DSP granularity of last-generation devices inspires some reflexions. The trend towards larger granularity, otherwise visible in the increase of the LUT complexity, is motivated by Rent's law: Routing consumes a larger share of the resources in larger-capacity devices [3]. Another illustration is the top entry of the top 10 predictions⁴ for FFCMs in 2012: "FPGAs will have floating point cores". We hope this prediction will turn out to be wrong! Considering that GPUs already offer in 2009 massive numbers of floating-point cores, we believe that FPGAs should go further on their own way, which has always been the choice of flexibility. Flexi-

⁴<http://www.fccm.org/top10.php>

bility allows for application-specific mix-and-match between integer, fixed point and floating point [4], between adders, multipliers [8], dividers, and even more exotic operators [4]. The integer multipliers and squarers studied in this article are not intended only for floating-point multipliers and squarers, they are also needed pervasively in coarser, more exotic, more application-specific operators which are possible only in FPGAs.

For this reason, while acknowledging that the design of a new FPGA is a difficult trade-off between flexibility, routability, performance and ease of programming [3], we think FPGAs need smaller / more flexible DSP blocks, not larger ones.

References

- [1] Altera Corporation. *Stratix-II Device Handbook*, 2004.
- [2] Altera Corporation. *Stratix-III Device Handbook*, 2006.
- [3] F. de Dinechin. The price of routing in FPGAs. *Journal of Universal Computer Science*, 6(2):227–239, 2000.
- [4] F. de Dinechin, J. Detrey, I. Trestian, O. Creț, and R. Tudoran. When FPGAs are better at floating-point than microprocessors. Technical Report ensl-00174627, École Normale Supérieure de Lyon, 2007. <http://prunel.ccsd.cnrs.fr/ensl-00174627>.
- [5] A. Karatsuba and Y. Ofman. Multiplication of multi-digit numbers on automata. *Doklady Akademii Nauk SSSR*, 145(2):293–294, 1962.
- [6] D. Knuth. *The Art of Computer Programming, vol.2: Seminumerical Algorithms*. Addison Wesley, 3rd edition, 1997.
- [7] P. L. Montgomery. Five, six, and seven-term Karatsuba-like formulae. *IEEE Transactions on Computers*, 54(3):362–369, 2005.
- [8] D. Strenski. FPGA floating point performance – a pencil and paper evaluation. *HPCWire*, Jan. 2007.
- [9] Xilinx Corporation. *Virtex-5 FPGA XtremeDSP Design Considerations (v3.2)*, 2008.
- [10] Xilinx Corporation. *XtremeDSP for Virtex-4 FPGAs User Guide (v2.7)*, 2008.